

# Next Generation Wireless Networks- Challenges and Opportunities

---

---

---

**Abhay Karandikar**

**Department of Electrical Engineering  
Indian Institute of Technology-Bombay**

**Mumbai 400076- India**

**(karandi@ee.iitb.ac.in)**

# Outline

---

- ◆ Towards 4G
- ◆ Technologies for 4G
- ◆ Research Issues in 4G
- ◆ QoS and MAC Layer Scheduling
- ◆ TTSL-IITB Center for Excellence in Telecom (TICET)
  - ◆ Our contributions in 802.16m

# Evolution of Cellular System

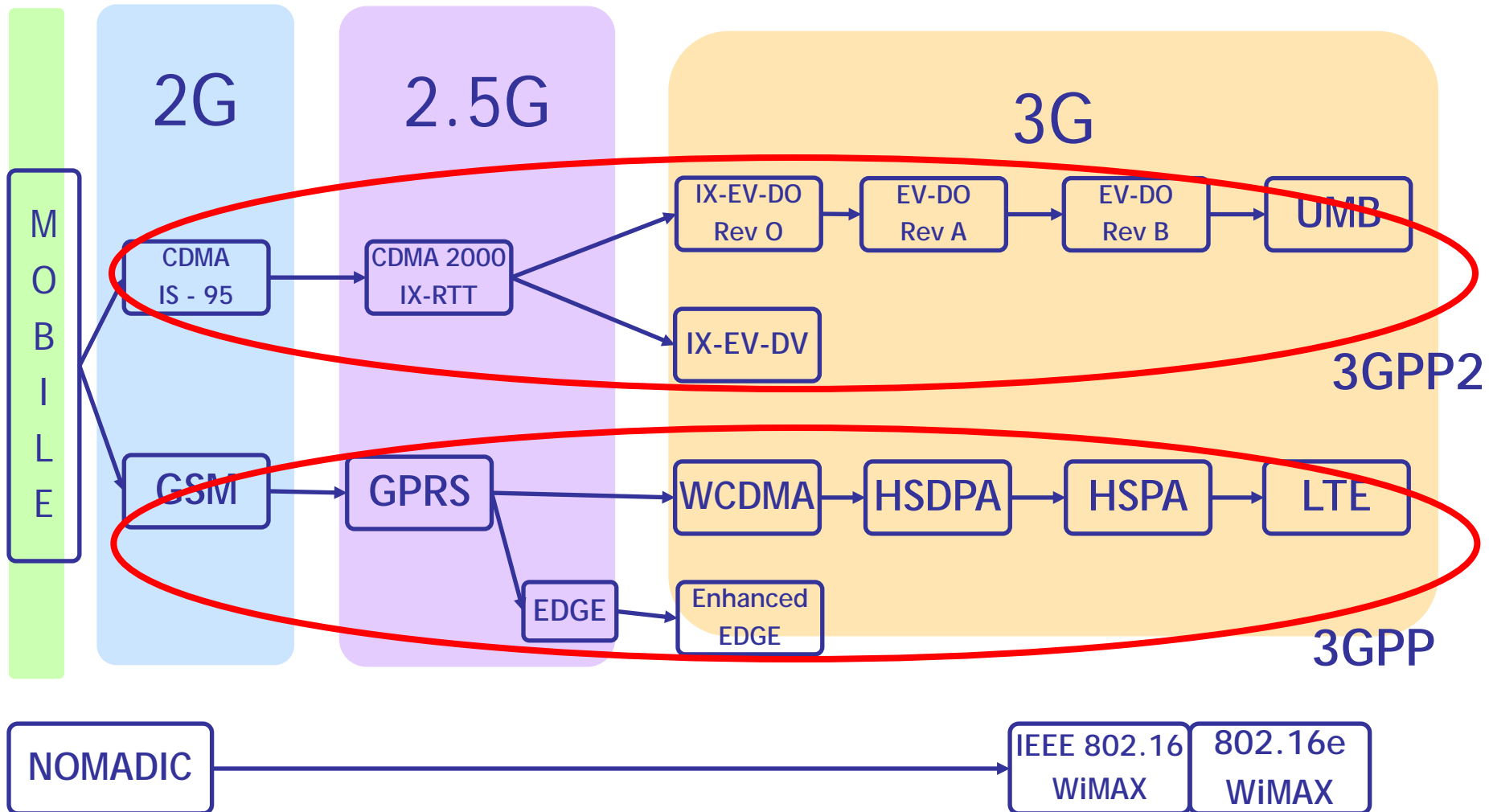

# Wireless Broadband

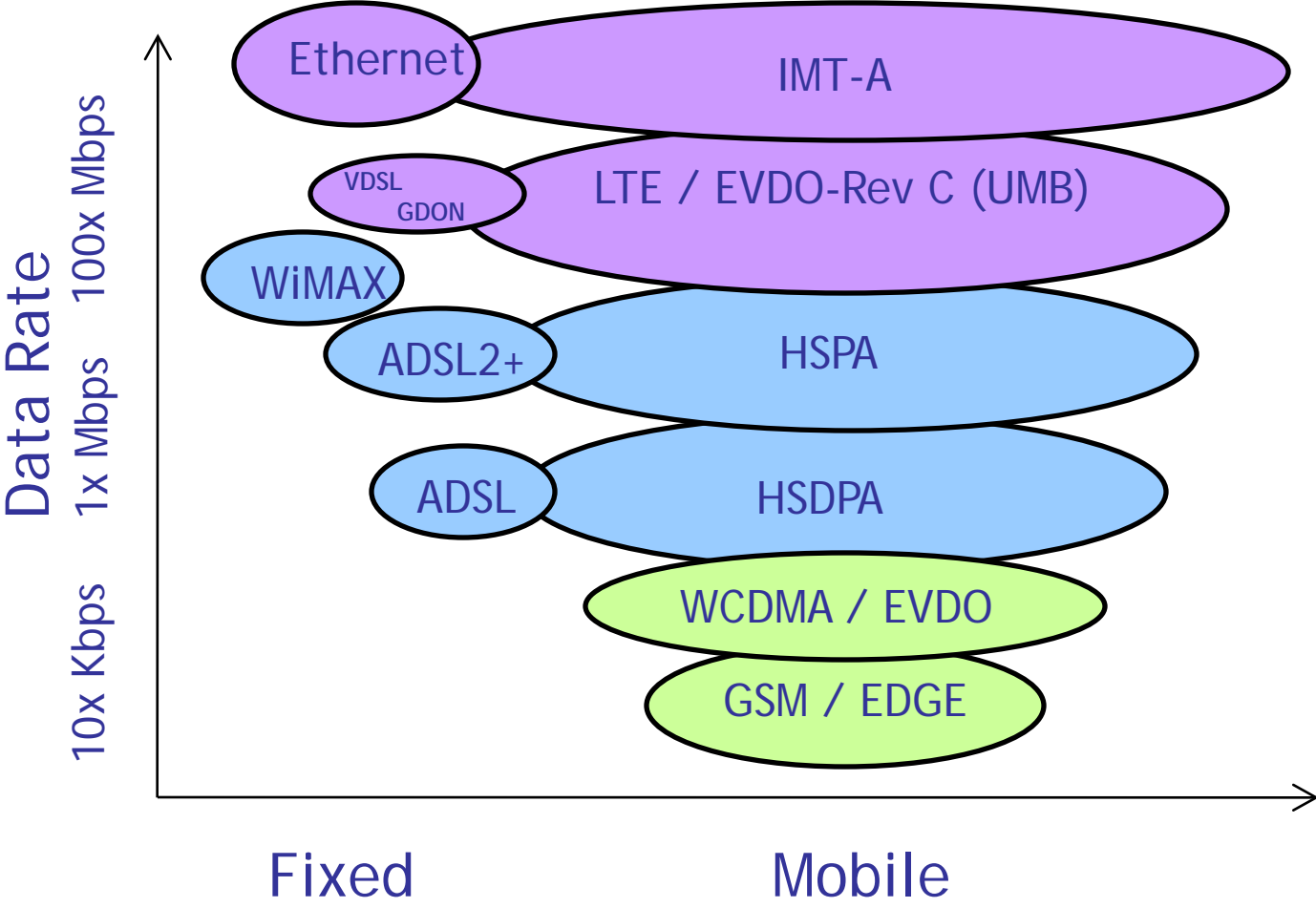

# IMT-Advanced = 4G = Broadband Wireless

---

## ◆ Peak Spectral Efficiency

- 15 bps/Hz - DL
- 6.75 bps/Hz UL

## ◆ Operating Bandwidth

- 5 to 100 MHz

## ◆ Cell Edge Spectral Efficiency

- 0.06 bps/Hz - DL
- 0.03 bps/Hz - UL

## ◆ Mobility (bps/Hz at Km/hr)

- 0.55 at 120 Km/hr
- 0.25 at 350 Km/hr

## ◆ Latency

- Control plane < 100 ms
- Data plane < 10 ms

## ◆ VoIP Capacity

- 40 active users / MHz / sector

## ◆ Spectrum (IMT Bands)

- 450 - 3600 MHz bands

# Outline

---

- ◆ Towards 4G
- ◆ **Technologies for 4G**
- ◆ Research Issues in 4G
- ◆ QoS and MAC Layer Scheduling
- ◆ Cross Layer Design

# Technology Components for 4G - Physical Layer

- ◆ OFDMA

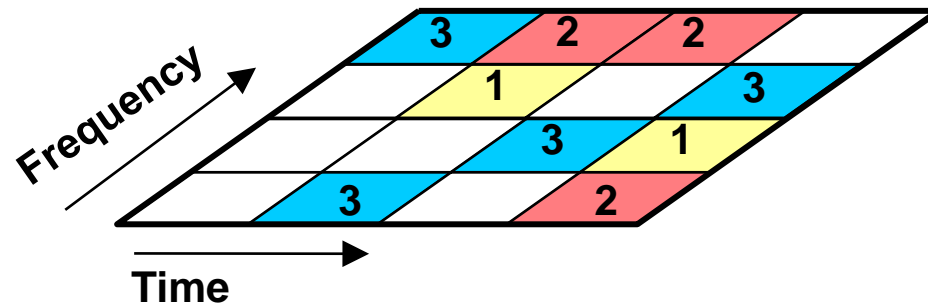

- ◆ Multi-Antenna (MIMO)

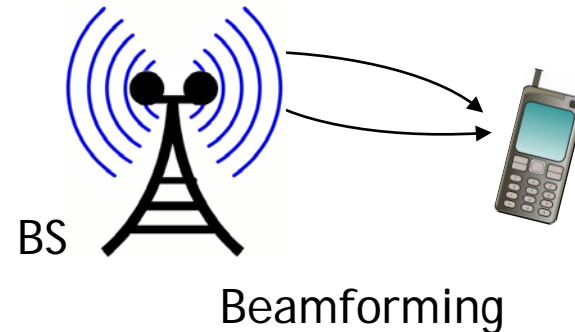
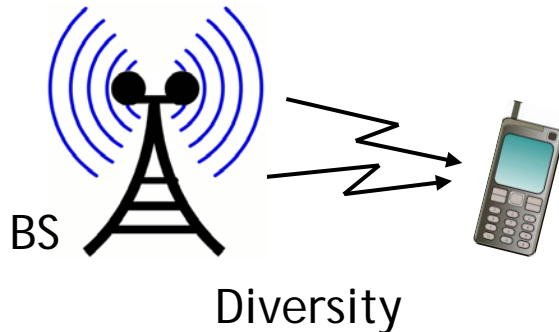

- ◆ Link Adaptation (adaptive modulation and coding)

# Technology Components for 4G - Physical Layer

- ◆ Spectrum flexibility and Carrier aggregation

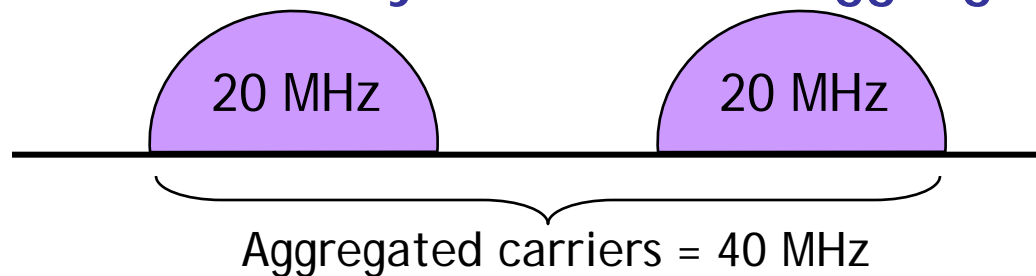

- ◆ Relaying

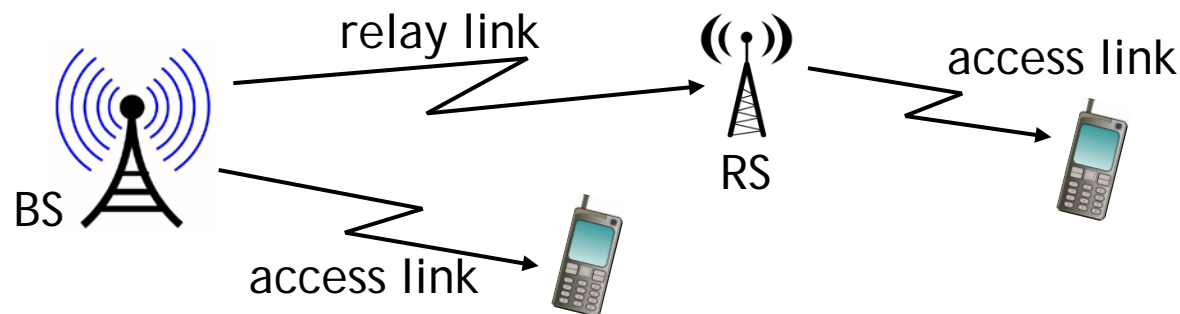

- ◆ Coordinated Multipoint transmission

- ◆ Geographically distributed antennae coordinate



# Technology Components for 4G - MAC Layer

---

- ◆ Fractional Frequency Reuse
- ◆ Enhanced Quality of Service support
  - ▶ End to End delay optimization
- ◆ Self organization and Self optimization
  - ▶ Plug and Play form of operation
- ◆ Peer to Peer and Network Coding
  - ▶ Originally proposed to increase the information flow by packet combining at intermediate nodes

# 4G Candidates

---

- ◆ Two candidates
  - ◆ 3GPP LTE-Advanced
  - ◆ IEEE 802.16m (Mobile WiMAX)
- ◆ Both are OFDMA based
- ◆ Both have TDD and FDD support

We will focus on some features of evolving 802.16m

# Key Features of IEEE 802.16m Mobile WiMAX

---

- ◆ High flexibility through support of both TDD & FDD
- ◆ Support of Multi Carrier Operation
- ◆ All IP Core network architecture
- ◆ Support for Advanced Relaying
- ◆ Multicast and Broadcast services
- ◆ Enhanced QoS features

# Outline

---

- ◆ Towards 4G
- ◆ Technologies for 4G
- ◆ **Research Issues in 4G**
- ◆ QoS and MAC Layer Scheduling
- ◆ Cross Layer Design

# Key Research Issues in WiMAX / 4G

---

- ◆ **High spectral efficiency at Cell Edge**
  - Interference coordination and cancellation
  - Adaptive fractional frequency reuse
  - Network MIMO
  - Intelligent scheduling
- ◆ **Multi hop Cellular Communication**
  - Relay for delay sensitive application
  - Network Coding and Cooperative Communication
- ◆ **Self organization**
  - Multidimensional / multivariable problem
- ◆ **Energy Efficiency**
- ◆ **QoS**

# Outline

---

- ◆ Towards 4G
- ◆ Technologies for 4G
- ◆ Research Issues in 4G
- ◆ **QoS and MAC Layer Scheduling**
- ◆ Cross Layer Design

# Wireless Uplink Scheduling

---

# Adaptive Granting and Polling Service

---

- ◆ Allows re-negotiation of traffic and QoS parameters and change of Grant size and Polling interval
- ◆ Adaptation methods
  - ◆ Implicit
  - ◆ Explicit (Trigger by explicit signaling)

We recently made contributions to 802.16m standard for Bandwidth Reservation protocol (Contribution accepted into AWD in July 2009)



# Bandwidth Request (BR) Procedure- IEEE 802.16m-09/0010r2 (AWD)

---

- ◆ Advanced Mobile Station (AMS) transmits a BR message, in random access mode within the contention window
- ◆ Common BR channel for all AMSs
- ◆ AMS performs retries if bandwidth is not granted
- ◆ Contention window doubled with every retry
- ◆ Drawbacks
  - No differentiation in window size based on service class
  - Lacks fairness- New users can get channel before old users
  - Scaling factor of 2 is used independent of system load

# Our BR Proposal (IEEE C80216m-09\_1321r4)

---

- ◆ Define *Connection Priority (CP)* for each contending Service Flow
- ◆ CP is a function of Service Class & Number of Retries (BR collisions)
- ◆ CP parameters:
  - Service Class
  - Initial / Maximum Window Size
  - Window Scaling Factor

# ARQ Support For Relays (IEEE P802.16m/D2)

---

- ◆ ARQ runs independently on both relay link (ABS-ARS) and access link (ARS-AMS)
- ◆ ABS clears buffer on ACK from ARS
- ◆ ARS clears buffer on ACK from AMS
- ◆ Drawback- Handover of AMS leads to packet loss

# Packet Loss In Handover

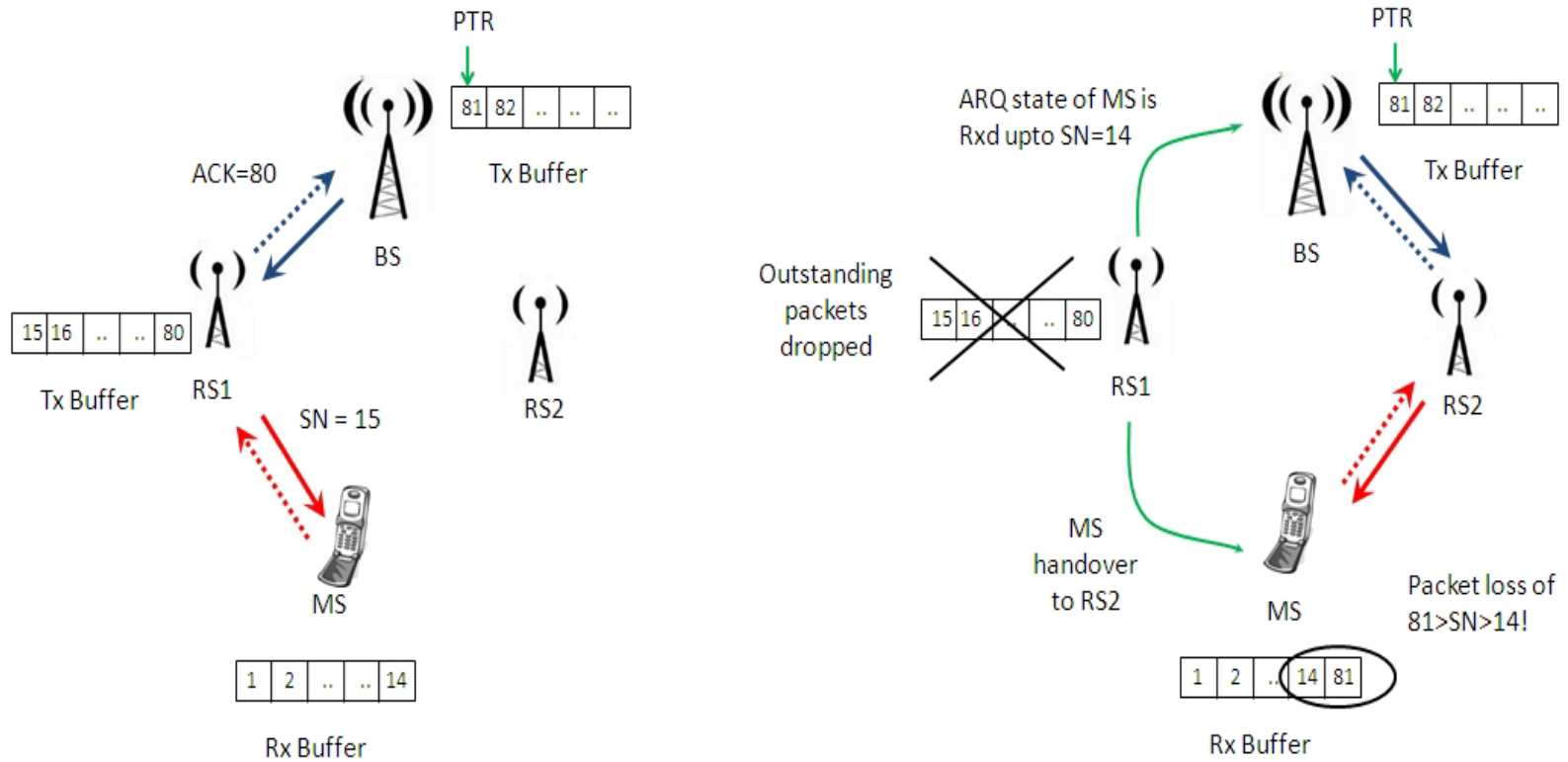

# Our ARQ Proposal

## (IEEE C802.16m-09/2229r1)

---

- ◆ ARQ feedback of AMS is forwarded to ABS by ARS
- ◆ ABS maintains ARQ states of both ARS and AMS
- ◆ ABS clears buffer only when AMS has successfully received the packet

# Our ARQ Proposal (IEEE C802.16m-09/2229r1)

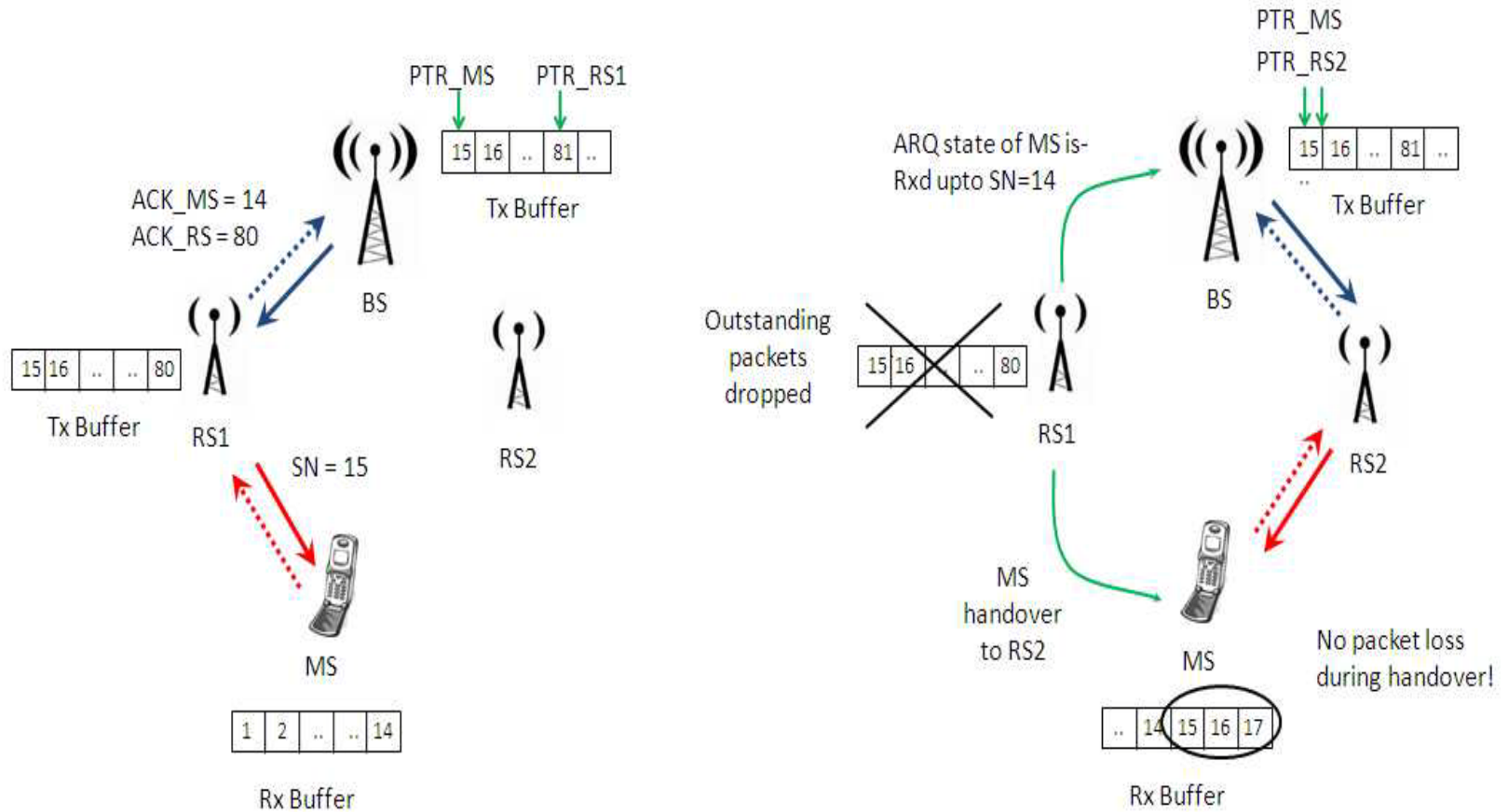

# Conclusions- Way Forward

---

- ◆ 4G Standards are evolving
- ◆ Lot of opportunities to contribute in International standards
- ◆ Focus- more spectral efficiency using both physical layer and MAC layer mechanisms
- ◆ Emerging areas
  - Intelligent scheduling for cooperative communications
  - Self organizing network (SoN)
  - Dynamic Spectrum Management
  - Peer to Peer applications and network coding
  - Distributed antenna system
  - QoS Mechanics for Delay Sensitive and Delay optimization